



Most Trusted Traveling Irrigation Systems
Since 1964

Kifco Model T200L Water-Reel®



- Turbine Driven Water-Reel® with 1.9" ID x 580' MDPE Tube
- Simple, reliable, portable irrigation for sport fields, golf courses pastures, hobby farms, small agriculture ranches and construction sites
- Automatic shutoff allows for unattended operation
- Mechanical levelwind system with miswrap safety for uniform, reliable tube rewinding
- Rugged construction proven by over 40 years of production and over 35,000 Kifco Water-Reels® sold
- Industry leading products with service and distribution at over 200 authorized dealers

Applicable Markets



Sports Fields and Golf Courses



Hobby Farms, Ranches and Pastures



Small Agriculture

Standard Features and Benefits

- The Kifco Model T200L uses a turbine drive which operates as low as 60 psi and 28 gpm (only 10 psi or less used in the turbine) and features simple and accurate speed control making it the most efficient turbine in the market
- Sprinkler selector valve easily allows for automatic sprinkler shutoff at the end of the run or continued operation
- Three wheeled chassis for extra stability and three large flotation tires make transport by small garden tractor or utility vehicle simple

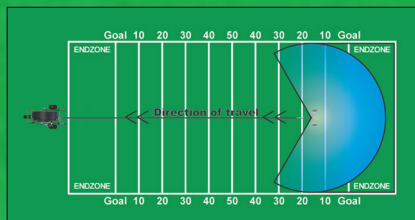

Easy Operation



Local Parts & Service

1 Year
Manufacturer's Warranty
5 Year
Pro Rated Tube Warranty



Engineered in the USA

www.kifco.com



700 S. Schrader Ave.
P.O. Box 290
Havana, IL 62644
800-452-7017 Toll Free
309-543-4425 Phone
309-543-4945 Fax



T200L Dimensions - T5 Chassis

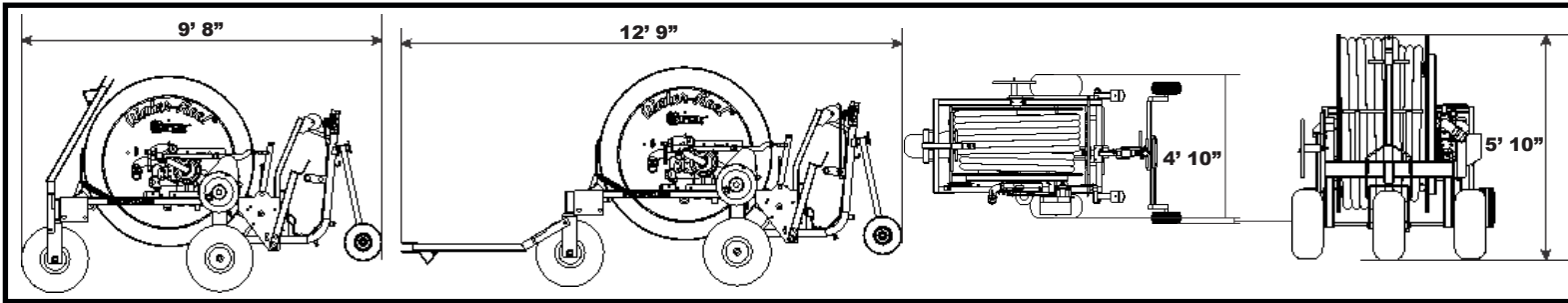

Technical Specifications

Tube Inner Diameter/Length	1.9" x 580'
Irrigated Width	110' - 211'
Irrigated Length	635' - 686'
Irrigated Area Per Run (Acres)	1.6 - 3.3
Drive System	Turbine
GPM Range	28 - 115
Inlet PSI Range	60 - 149
Hours Per Full Run	4.6 - 27
Retraction Speed	21.5 - 126 ft. per hour
Dry Weight (lbs)	1,290
Weight With Water (lbs)	2,000
Inlet Diameter	2" Male Camlock
Supply Hose	15' 2" Male x Female Camlock

Options

Reel-Mounted Booster Pumps	5.5Hp Gas, 9Hp Gas
Stand-Alone Boosters	5Hp
Primary Pumps	23Hp Gas, 21Hp Gas or 35Hp Gas
Stiff Tongue & Jack Kit	Bolt on kit for easy transport in rough terrain
Guncart Wheel Upgrade	16" wheels - added stability in rough terrain

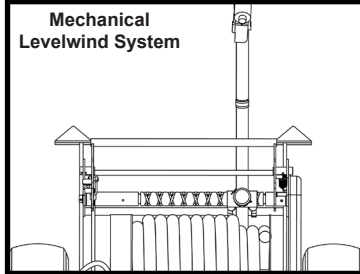
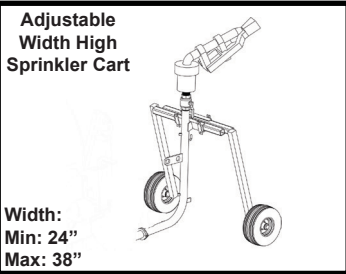

Standard Connection

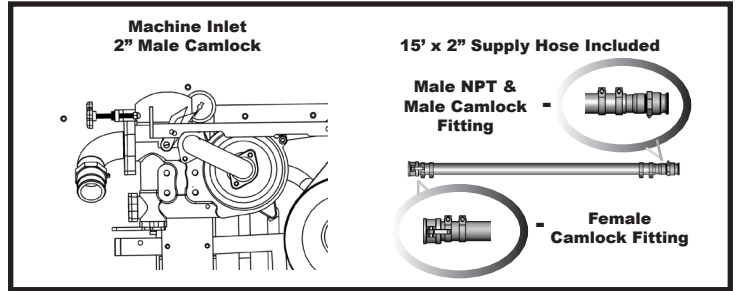

Sprinkler Model	Nozzle Dia.	Inlet PSI	(Q) GPM	Width (ft.) (80%)	Length (ft.) (80%)	Wetted Dia. (ft.)	Application Rate (in.)
Komet Twin Max	0.51"	65	47	154	657	193	0.3 - 1.4
	0.51"	92	58	177	668	221	0.3 - 1.4
	0.51"	119	67	198	679	248	0.3 - 1.4
	0.55"	70	55	161	660	201	0.3 - 1.6
	0.55"	99	67	183	672	229	0.3 - 1.6
	0.55"	129	78	206	683	257	0.3 - 1.6
	0.63"	84	72	173	666	216	0.3 - 1.6
	0.63"	119	88	198	679	247	0.3 - 1.6
	0.63"	136	95	210	685	262	0.4 - 1.6
	0.67"	82	76	171	666	214	0.4 - 1.6
	0.67"	121	95	199	680	249	0.4 - 1.6
	0.67"	140	103	211	686	264	0.4 - 1.6
	0.71"	91	85	177	668	221	0.4 - 1.6
	0.71"	112	96	194	677	242	0.4 - 1.6
0.71"	135	107	206	683	258	0.4 - 1.6	

Sprinkler Performance

Sprinkler Model	Nozzle Dia.	Inlet PSI	(Q) GPM	Width (ft.) (80%)	Length (ft.) (80%)	Wetted Dia. (ft.)	Application Rate (in.)
Nelson SR75	0.55"	61	49	138	649	172	0.3 - 1.4
	0.55"	97	64	166	663	208	0.3 - 1.4
	0.55"	125	74	187	674	234	0.3 - 1.6
	0.60"	68	59	142	651	178	0.4 - 1.6
	0.60"	108	77	176	668	220	0.4 - 1.6
	0.60"	140	89	195	678	244	0.4 - 1.6
	0.65"	76	69	153	656	191	0.4 - 1.6
	0.65"	122	91	182	671	228	0.4 - 1.6
	0.65"	148	101	194	677	243	0.4 - 1.6
	0.70"	98	87	163	662	204	0.6 - 1.6
	0.70"	141	104	190	675	237	0.6 - 1.6
	0.75"	109	98	170	665	213	0.6 - 1.6
	0.75"	145	115	184	672	230	0.6 - 1.6

Sprinkler Model	Nozzle Dia.	Inlet PSI	(Q) GPM	Width (ft.) (80%)	Length (ft.) (80%)	Wetted Dia. (ft.)	Application Rate (in.)
Sime Hidra	10mm	60	28	110	635	137	0.3 - 1.6
	10mm	76	33	118	639	148	0.3 - 1.6
	12mm	70	48	126	643	157	0.3 - 1.6
	12mm	90	56	142	651	177	0.3 - 1.6
	12mm	108	62	158	659	197	0.3 - 1.6
	14mm	80	63	131	646	164	0.4 - 1.6
	14mm	103	73	152	656	190	0.4 - 1.6
	14mm	126	82	162	661	203	0.4 - 1.6
	16mm	94	80	137	648	171	0.4 - 1.6
	16mm	123	93	158	659	197	0.4 - 1.6
	16mm	148	103	173	666	216	0.6 - 1.6
	18mm	116	100	147	654	184	0.6 - 1.6
	18mm	149	115	162	661	203	0.6 - 1.6

Maximum 10 PSI turbine pressure loss is assumed in all data. Area covered may vary depending on wind conditions, and use of different sprinklers. Specifications are subject to change without notice. Technical specifications contained herein are based upon sprinkler manufacturer's recommended pressure and flow. Actual specifications may vary.